



**VF, VFT,  
VFH**

**Butterfly valves  
Rp3/4 ... Rp2  
DN40 ... DN200**



# VF, VFT VFH

## Butterfly valves

### Contents

Description .....	2
Features .....	2
Functioning and application .....	3
Technical specifications .....	4
Flow chart (pressure drop) .....	7
Flow velocity chart .....	9
Flow factor $K_{VS}$ .....	10
Ordering information .....	12
Standards and approvals .....	12

### Description

VF, VFT and VFH butterfly valves are designed for regulation and control of gas flow and air flow in combustion processes.

Valves can be operated manually using a lever (to setup the high-fire rate of the burner) or automatically using a servomotor (modulating or staged control) or a solenoid actuator (two-stage control).

### Features

Valves are made of aluminum casting (VF/VFT type) or cast-iron (VFH type), with wide range of threaded connections and for installation between EN 1092 flanges.

Possibility to have one-size or two-size reductions of the nominal diameter for VF/VFT type.

Suitable for use with air and non-aggressive gases according to EN 437 (VF/VFT type); heated air and flue gas (VFH type).

Low leakage when valve is in closed position (VFH type provided with butterfly disc stop).

The VFH type is provided with a double-eccentricity disc and a spring to reduce the play. This results in an high precision adjustment and avoids valve floating.

Operated by manual lever, servomotor or by solenoid actuator.

All components are designed to withstand any mechanical, chemical, thermal condition occurring during typical service. Effective impregnation and surface treatments have been used to improve mechanical sturdiness, sealing and resistance to corrosion of the components.



### WARNING

This control must be installed in compliance with the rules in force.

## Functioning and application

VF/VFH butterfly valves are devices for regulation/modulation using auxiliary power supply or manually operated.

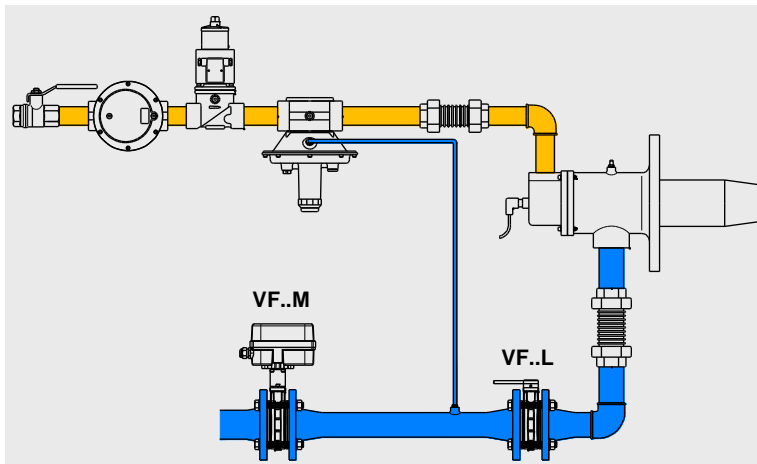

Fig. 1

- in case of combustion process being regulated by combustion air modulation, VF valves with servomotor can be used, coupled to another butterfly valve manually operated (available graduated scale and locking screw) to setup high-fire rate of the burner.

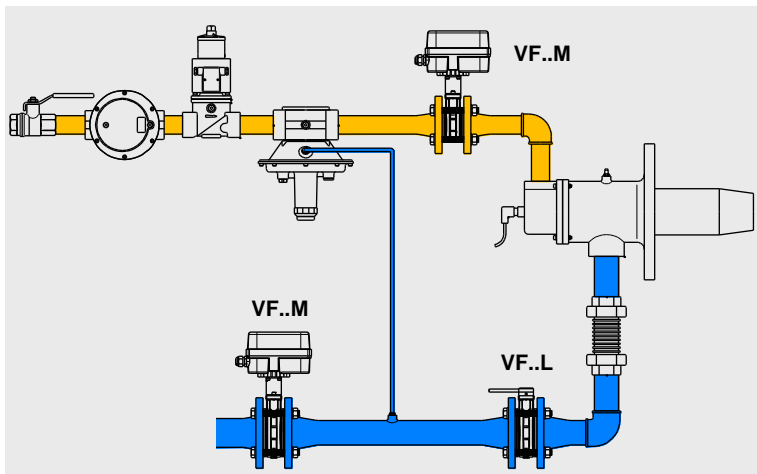

Fig. 2

- In case of combustion process with excess of air or gas, VF butterfly valve can be used, coupled to a Lambda sensor for ratio correction.

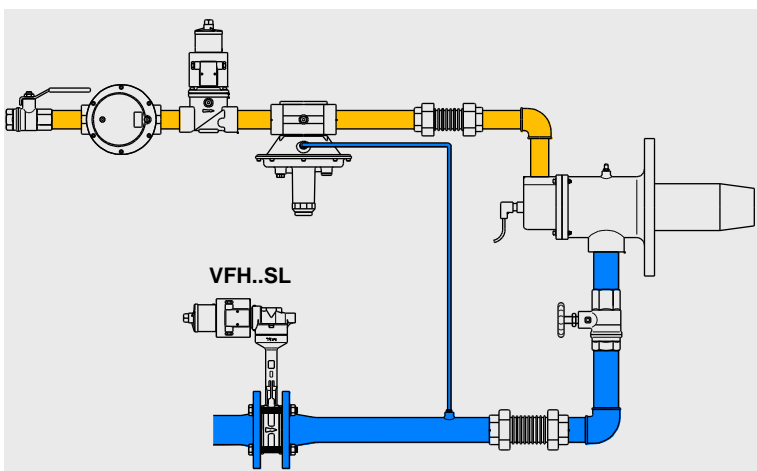

Fig. 3

- In case of combustion process with pre-heated air, VFH butterfly valve can be used. Solenoid actuator is preferentially suitable for min/max regulation with heavy duty cycles.



### WARNING

Location and mode of installation must be in compliance with local rules in force.

**Technical specification**

Tab. 1

	VF, VFT	VFH
<b>Connections</b>	Threaded from Rp3/4 to Rp2 according to EN 10226-1 From DN40 up to DN150 for fitting between two flanges according to EN 1092 PN16	From DN40 up to DN200 for fitting between two flanges according to EN-1092 PN16
<b>Rotation angle</b>	0 / 90° adjustable	0 / 90° adjustable
<b>Ambient temperature</b>	-15°C / +60°C	-15°C / +60°C
<b>Media type</b>	Air and non-aggressive gases according EN 437	Heated air and flue gas
<b>Max. media temperature</b>	+60°C +200°C for use with air only (special version on request)	+250°C +450°C with dissipators
<b>Max. operating pressure</b>	500 mbar (50 kPa)	150 mbar (15 kPa)
<b>Max. differential pressure</b>	150 mbar (15 kPa)	45 mbar (4,5 kPa)
<b>Flow rate</b>	See tables	See tables
<b>Materials in contact with fluid</b>	Aluminum alloy Copper alloy Stainless steel Nitrile rubber (NBR) Fluoroelastomer (FPM) Polytetrafluoroethylene (PTFE)	Cast iron Stainless steel Polytetrafluoroethylene (PTFE)
<b>Driving systems and actuators</b>	<ul style="list-style-type: none"> <li>- square shaft □8</li> <li>- round shaft Ø10</li> <li>- manual lever</li> <li>- solenoid SR/SL/ST</li> <li>- servomotor MZ</li> <li>- servomotor MZ with lever</li> </ul>	<ul style="list-style-type: none"> <li>- manual lever</li> <li>- solenoid SR/SL/ST</li> <li>- servomotor MZ</li> </ul>

VF VFT	Rp3/4	Rp1	Rp1¼	DN40 Rp1½	DN50 Rp2	DN65	DN80	DN100	DN125	DN150	DN200
S..4	●	●	●	●	●	●					
S..8							●	●	●	●	
MZ	●	●	●	●	●	●	●	●			
MZ...10									●	●	

VFH	Rp3/4	Rp1	Rp1¼	DN40	DN50	DN65	DN80	DN100	DN125	DN150	DN200
S..4				●	●						
S..8						●	●	●			
MZ				●	●	●	●	●			
MZ...10									●	●	●

**Fitting between two flanges according to EN-1092 PN16**

**Fitting onto threaded pipelines**

Fig.4

**VFT**
**VF**

Fig.5

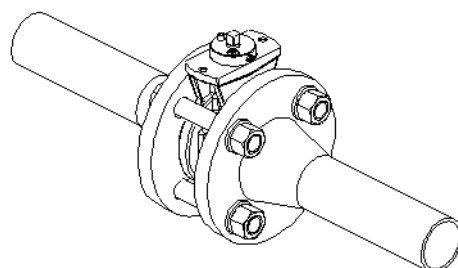
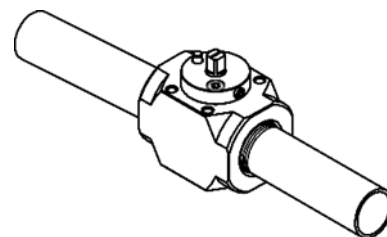
Tab. 2

Connections	Overall dimensions [mm]					Weight <sup>1</sup> [Kg]	Actuator	Overall dimensions [mm]			Weight [Kg]
	CH	P	De	L1	L2			L3	H	Ø	
Rp 3/4	50	70				0,45					
Rp 1	50	70				0,40					
Rp 1 1/4	65	85				0,75					
Rp 1 1/2	65	85				0,65					
Rp 2	75	90				0,80					
DN 40			92	46	80	0,8	SR4	126	160	100	5,0
DN 50			107	53,5	87,5	0,9	SL4	126	230	100	5,5
DN 65			127	63,5	97,5	1,2	ST4	126	240	100	5,6
DN 80			142	71	105	1,3	SR8	134	182	114	7,2
DN 100			162	81	115	1,5	SL8	134	252	114	7,7
DN 125			192	96	130	1,8	ST8	134	262	114	7,8
DN 150			217	108,5	147,5	2,2	MZ				2,0

(1) Actuator weight excluded (adapter for VF..S 0,55Kg)

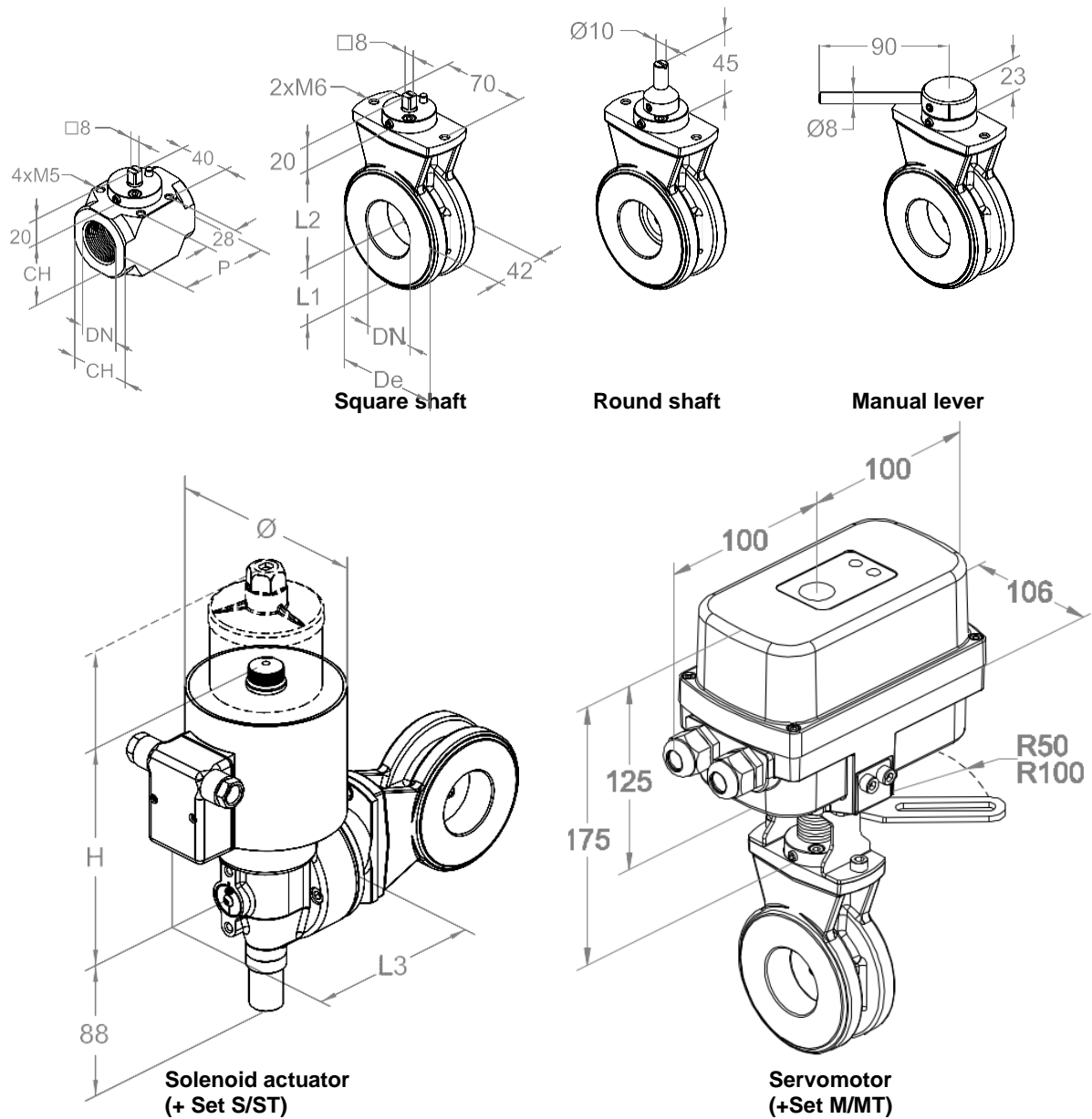
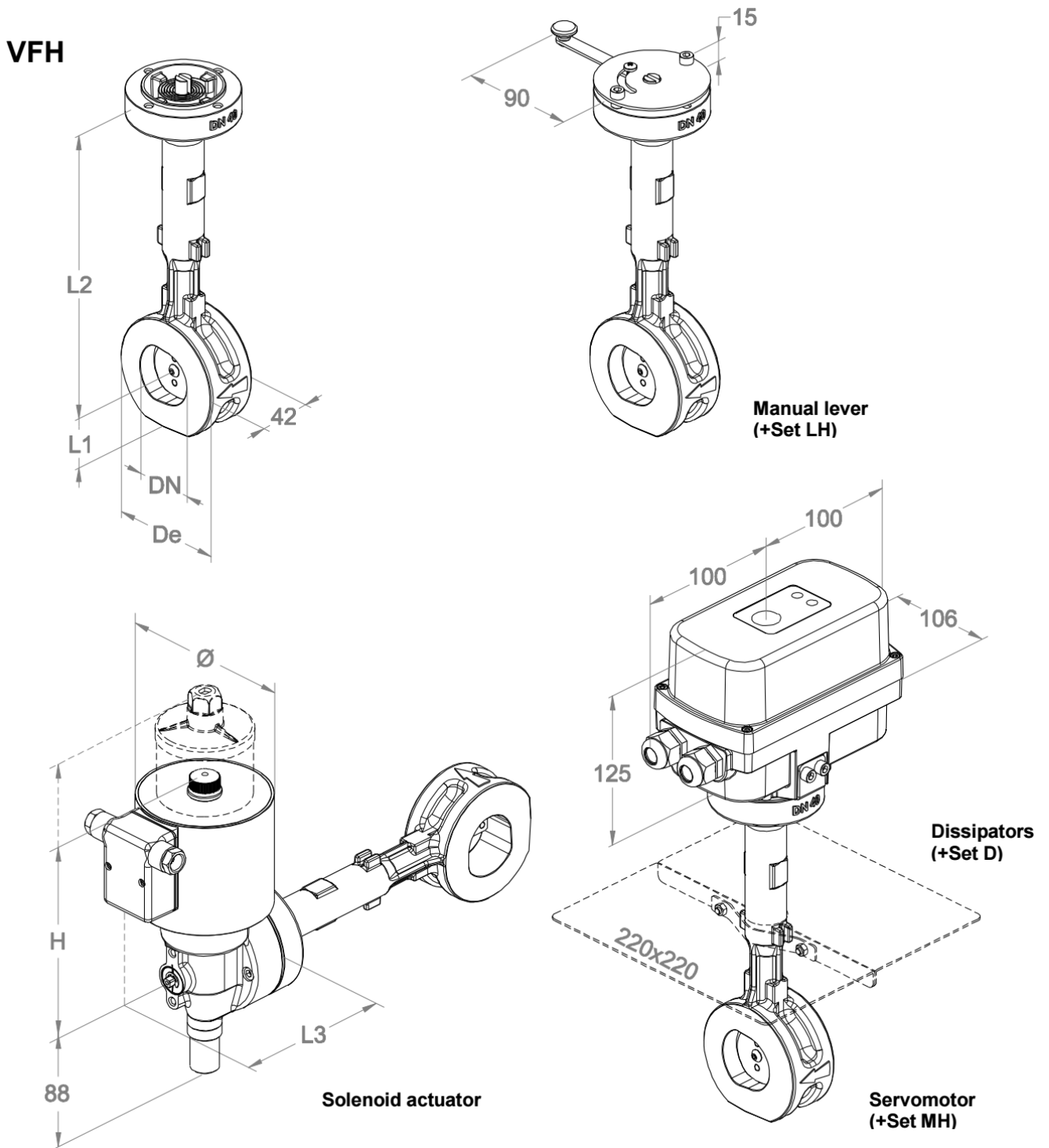

Fig.6

Tab. 3

Connections	Overall dimensions [mm]			Weight <sup>(1)</sup> [Kg]	Actuator	Overall dimensions [mm]			Weight [Kg]
	De	L1	L2			L3	H	Ø	
DN 40	92	42	230	2,9	SR4	126	160	100	5,0
DN 50	107	49,5	237,5	3,3	SL4	126	230	100	5,5
DN 65	127	59,5	247,5	3,9	ST4	126	240	100	5,6
DN 80	142	67	255	4,3	SR8	134	182	114	7,2
DN 100	162	81	265	4,8	SL8	134	252	114	7,7
DN 125	192	99	275	7,2	ST8	134	262	114	7,8
DN 150	217	111	287	8,2	MZ				2,0
DN 200	275	140	315	11					

(1) Actuator weight excluded

## Flow chart - VF, VFT

- blue lines: leakage @ 0° opening angle
- orange lines: max flowrate @ 90° opening angle

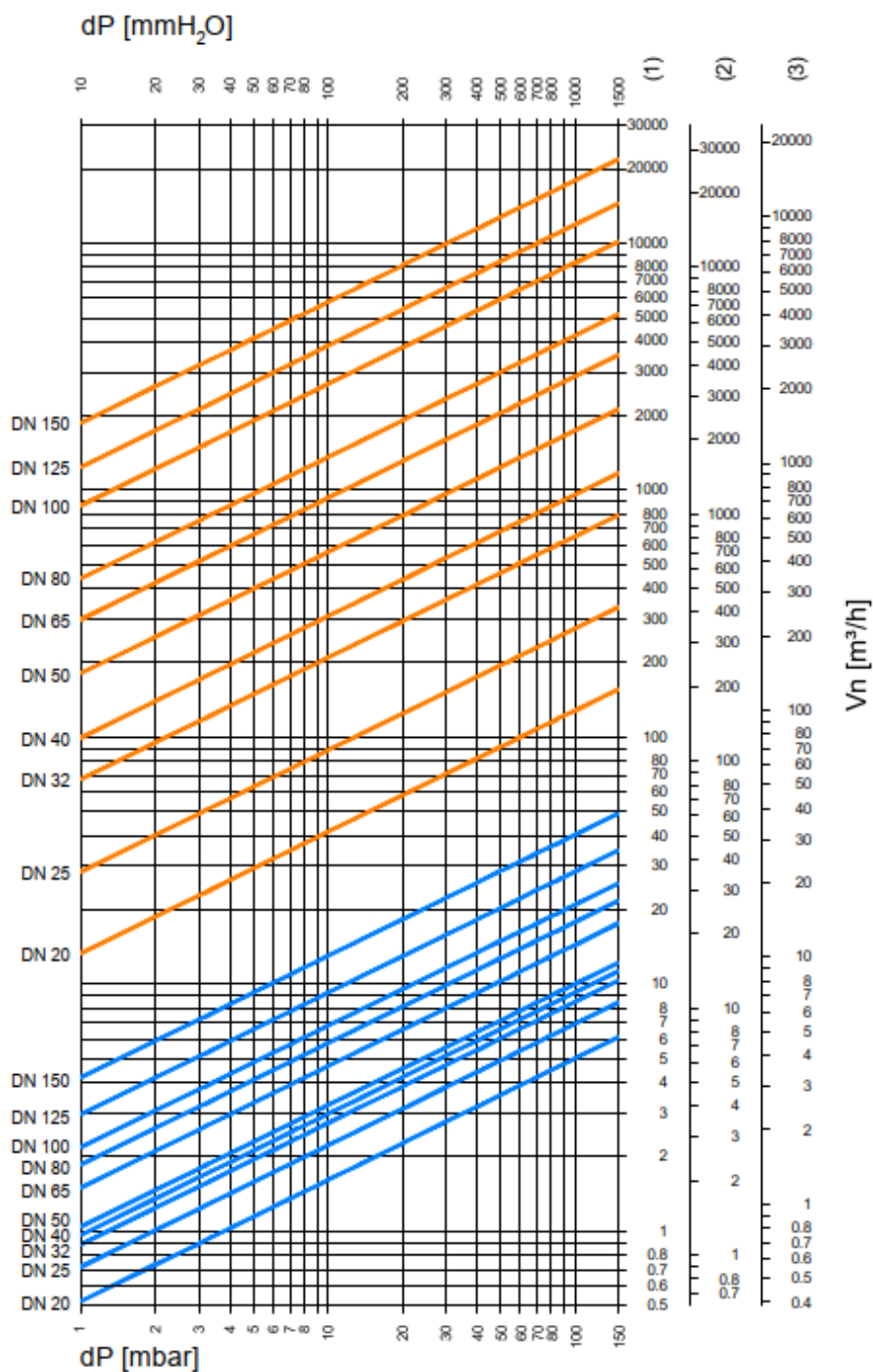

Fig.7

### Formula of conversion from air to other gases

$$V_{GAS} = k \cdot V_{ARIA}$$

Tab. 4

Gas type	Specific gravity $\rho$ [Kg/m <sup>3</sup> ]	$k = \sqrt{\frac{1.25}{\rho_{GAS}}}$
Air	1,25	1,00
Natural gas	0,80	1,25
Town gas	0,57	1,48
LPG	2,08	0,77

15°C, 1013 mbar, dry

## Flow chart - VFH

- **blue lines:** leakage @ 0° opening angle
- **orange lines:** max flowrate @ 90° opening angle

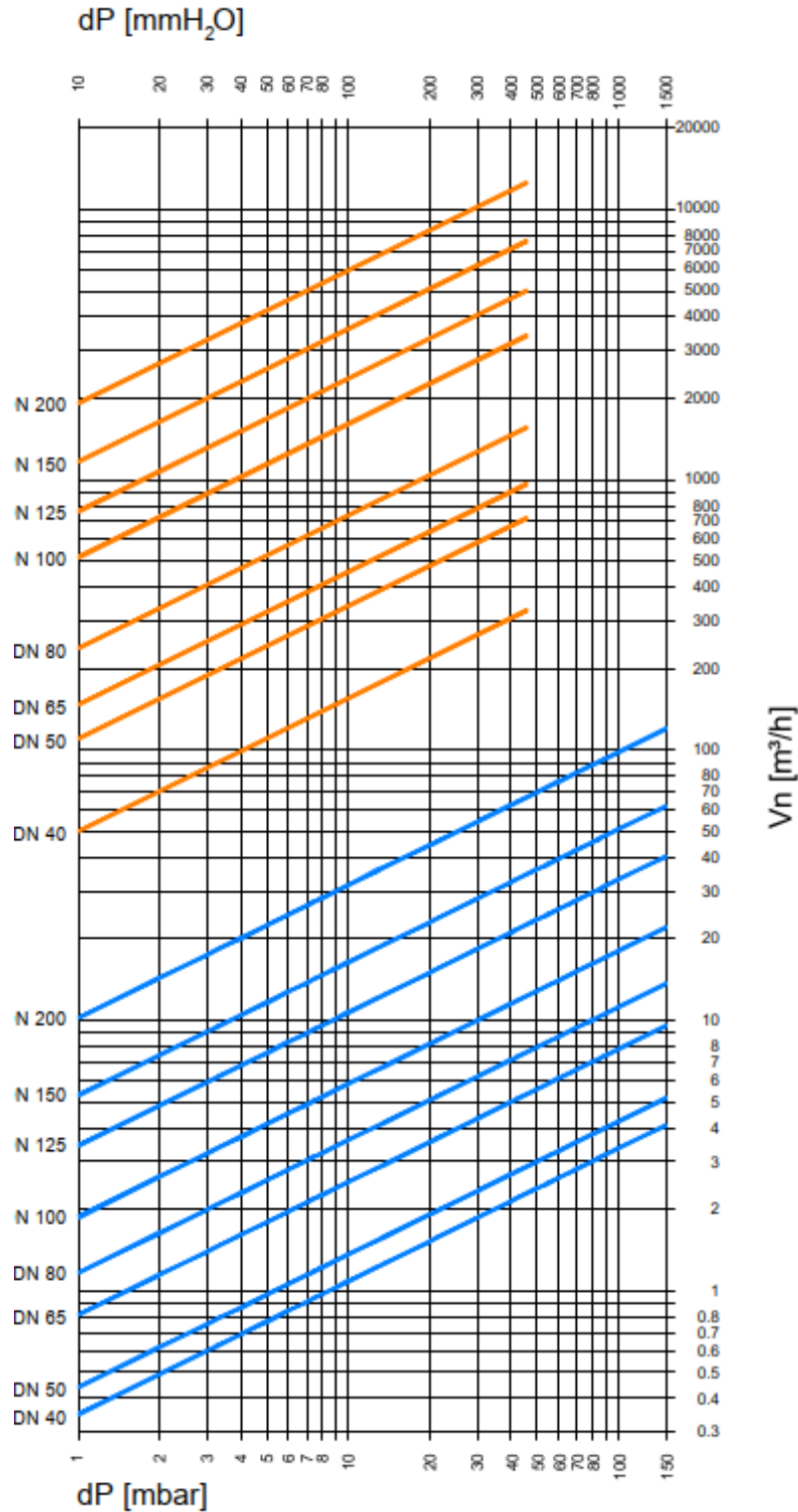

Fig.8



Pressure drop ( $\Delta p$ ) being 30% of inlet pressure ( $p_1$ ) assures a good flow control.



**Flow velocities chart**

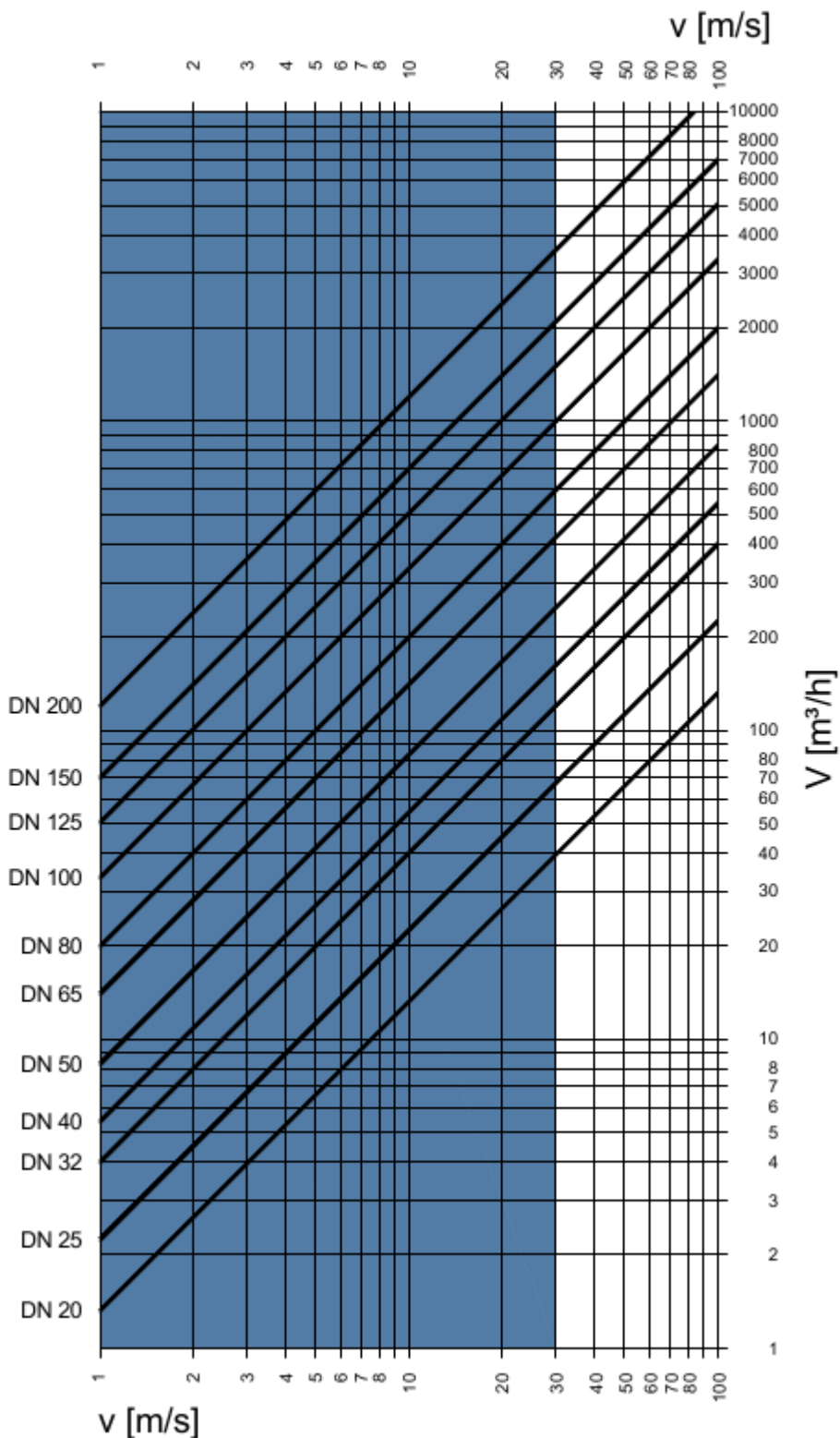

Fig.9



Flow velocity lower than 30 m/s is recommended to avoid noise and turbulence that can affect pressure drop.

## Flow factor Kvs

(15°C, 1013 mbar, dry)

### VF, VFT type

Tab. 5

Connection	Reduction	Opening angle									
		0°	10°	20°	30°	40°	50°	60°	70°	80°	90°
<b>Rp 3/4</b>	<b>DN 20</b>	<b>0.6</b>	<b>0.8</b>	<b>1.0</b>	<b>2.1</b>	<b>3.5</b>	<b>6.4</b>	<b>8.2</b>	<b>10.3</b>	<b>11.2</b>	<b>12.5</b>
<b>Rp1</b>	DN 20	0.6	0.8	1.0	2.1	3.5	6.4	8.2	10.3	11.2	12.5
	<b>DN 25</b>	<b>0.8</b>	<b>1.0</b>	<b>1.5</b>	<b>4.0</b>	<b>6.5</b>	<b>10.7</b>	<b>16.5</b>	<b>23</b>	<b>27</b>	<b>29</b>
<b>Rp 1 1/4</b>	DN 20	0.6	0.8	1.0	2.1	3.5	6.4	8.2	10.3	11.2	12.5
	DN 25	0.8	1.0	1.5	4.0	6.5	10.7	16.5	23	27	29
	<b>DN 32</b>	<b>1.0</b>	<b>1.4</b>	<b>2.8</b>	<b>5.4</b>	<b>9.5</b>	<b>16</b>	<b>27</b>	<b>41</b>	<b>57</b>	<b>63</b>
<b>Rp 1 1/2</b> <b>DN 40</b>	DN 25	0.8	1.0	1.5	4.0	6.5	10.7	16.5	23	27	29
	DN 32	1.0	1.4	2.8	5.4	9.5	16	27	41	57	63
	<b>DN 40</b>	<b>1.1</b>	<b>1.5</b>	<b>3.6</b>	<b>7.3</b>	<b>13</b>	<b>23</b>	<b>37</b>	<b>56</b>	<b>77</b>	<b>90</b>
<b>Rp 2</b> <b>DN 50</b>	DN 32	1.0	1.4	2.8	5.4	9.5	16	27	41	57	63
	DN 40	1.1	1.5	3.2	7.1	13	21	34	52	73	90
	<b>DN 50</b>	<b>1.2</b>	<b>1.6</b>	<b>4.0</b>	<b>9.3</b>	<b>17</b>	<b>31</b>	<b>51</b>	<b>82</b>	<b>123</b>	<b>167</b>
<b>DN 65</b>	DN 40	1.1	1.5	3.3	7.1	13	20	32	46	61	71
	DN 50	1.3	1.6	4.3	9.5	17	29	46	68	97	120
	<b>DN 65</b>	<b>1.7</b>	<b>2.7</b>	<b>7.3</b>	<b>16</b>	<b>32</b>	<b>57</b>	<b>94</b>	<b>144</b>	<b>210</b>	<b>281</b>
<b>DN 80</b>	DN 50	1.3	1.6	4.0	9.0	16	28	44	64	85	101
	DN 65	2.0	2.4	7.0	16	31	55	89	132	185	243
	<b>DN 80</b>	<b>2.1</b>	<b>3.2</b>	<b>9.8</b>	<b>24</b>	<b>47</b>	<b>83</b>	<b>132</b>	<b>202</b>	<b>296</b>	<b>405</b>
<b>DN 100</b>	DN 65	2.0	2.9	7.7	17	32	55	86	122	162	185
	DN 80	2.4	3.3	9.8	23	49	88	140	203	275	335
	<b>DN 100</b>	<b>2.5</b>	<b>3.4</b>	<b>12</b>	<b>33</b>	<b>59</b>	<b>133</b>	<b>214</b>	<b>331</b>	<b>517</b>	<b>792</b>
<b>DN 125</b>	DN 80	2.4	3.4	8.7	22	47	85	133	185	237	273
	DN 100	2.9	5.2	17	48	103	173	262	364	478	561
	<b>DN 125</b>	<b>3.4</b>	<b>7.4</b>	<b>25</b>	<b>78</b>	<b>145</b>	<b>244</b>	<b>385</b>	<b>583</b>	<b>910</b>	<b>1132</b>
<b>DN 150</b>	DN 100	2.9	4.2	15	42	95	160	237	319	397	458
	DN 125	3.8	6.6	25	89	180	288	422	586	771	940
	<b>DN 150</b>	<b>4.7</b>	<b>13</b>	<b>58</b>	<b>132</b>	<b>229</b>	<b>369</b>	<b>583</b>	<b>882</b>	<b>1557</b>	<b>1696</b>

### VFH type

Tab. 6

Connection	Opening angle									
	0°	10°	20°	30°	40°	50°	60°	70°	80°	90°
<b>DN 40</b>	0,4	6,5	10	13	17	23	31	42	55	60
<b>DN 50</b>	0,5	10	14	18	25	36	51	75	108	120
<b>DN 65</b>	0,6	15	23	31	44	64	85	114	150	160
<b>DN 80</b>	0,8	24	35	46	63	96	137	190	243	260
<b>DN 100</b>	1,1	34	52	74	105	165	250	370	540	570
<b>DN 125</b>	3.9	50	74	105	150	235	355	525	760	810
<b>DN 150</b>	5.9	75	116	165	230	365	550	810	1170	1250
<b>DN 200</b>	11.4	125	190	270	380	595	905	1330	1920	2050

Valve dimension can be calculated using flow diagrams or using characteristic flow factor (Kvs) mentioned in tables 5 and 6 for several opening angles of the butterfly disc.

**Example (calculation using diagram):**

Target is to select a valve for air with  $p_2 = 50$  mbar and flow rate  $V = 800$  Nm<sup>3</sup>/h. DN100 pipes are advisable to avoid to overtake recommended flow velocity. Pressure drop will be:

$$\Delta p = \left( \frac{0.3}{1-0.3} \right) p_2 = 21.4 \text{ mbar}$$

VF diagram curves suggest that DN65 valve can assure the requested flow rate. Considering DN100 pipe diameter, version DN100/65 (double reduction) can be adopted.

**Example (calculation using flow factor Kvs):**

Target is to select a valve for air at 250°C temperature with  $p_2 = 30$  mbar and flow rate  $V_{MAX} = 200$  Nm<sup>3</sup>/h. DN50 pipes are advisable to avoid to overtake recommended gas speed. Pressure drop will be:

$$\Delta p = \left( \frac{0.3}{1-0.3} \right) p_2 \cong 13 \text{ mbar}$$

Valve identification requires the calculation of Kv factor under operating conditions. Considering subcritical pressure drops only:

$$\Delta p < \frac{p_1}{2}$$

Kv can be calculated with the formula:

$$K_V = \frac{V}{514} \sqrt{\frac{\rho(t+273)}{\Delta p \cdot p_{2A}}}$$

where:

- V = flow rate [Nm<sup>3</sup>/h]
- Kv = flow factor [m<sup>3</sup>/h]
- $\rho$  = density [Kg/m<sup>3</sup>]
- $p_{1A}$  = absolute inlet pressure [bar]
- $p_{2A}$  = absolute outlet pressure [bar]
- $\Delta p$  = differential pressure  $p_1 - p_2$  [bar]
- t = media temperature [°C]

$$K_V = \frac{200}{514} \sqrt{\frac{1.25(250+273)}{0.013 \cdot 1.043}} \cong 85$$

VFH valve (type for heated air) having  $K_{VS}$  just higher than  $K_V$  is DN 50 (table 6).

Considering a linear  $K_V$  behavior with opening angle, the required  $K_V$  value comes with an angle of about 72°.

Using the following formula it is now possible to determine the leakage rate with completely closed disc or the flow rate  $V_{MIN}$  with disc in minimum flow rate setting:

$$V = 514 \cdot K_V \cdot \sqrt{\frac{\Delta p \cdot p_{2A}}{\rho(t+273)}}$$

**Ordering information**

Tab.7

VF	VFT	VFH	Model	VF	4	1	R	
<b>Connection</b>								
⊗	●	⊗	2= Rp 3/4"					
⊗	●	⊗	3= Rp 1"					
⊗	●	⊗	35= Rp 1 1/4"					
⊗	●	⊗	4= Rp 1 1/2"					
⊗	●	⊗	6= Rp 2"					
●	⊗	●	4= DN40					
●	⊗	●	6= DN50					
●	⊗	●	7= DN65					
●	⊗	●	8= DN80					
●	⊗	●	9= DN100					
●	⊗	●	93= DN125					
●	⊗	●	95= DN150					
⊗	⊗	●	98= DN200					
<b>Reduction DN</b>								
●	●	●	= none					
○	○	⊗	1= 1xDN					
○	○	⊗	2= 2xDN					
<b>Max. Media temperature</b>								
●	●	⊗	= +60°C					
○	○	⊗	R = +200°C (air only)					
⊗	⊗	●	= +250°C					
⊗	⊗	①	= +450°C (with dissipators)				① Set D	
<b>Driving systems and actuators</b>								
●	●	⊗	- shaft □8					
①	①	⊗	- shaft Ø10 .....	① Set O				
②	②	③	- manual lever .....	② Set L		③ Set LH		
④	⑤	●	- solenoid SR/SL/ST .....	④ Set S		⑤ Set ST		
⑥	⑦	⑧	- servomotor MZ .....	⑥ Set M		⑦ Set MT	⑧ Set MH	
⑨	⑩	⊗	- servomotor MZ with lever	⑨ Set ML		⑩ Set MTL		
●	○	⊗	Standard      Optional      Not available					



Manufacturer reserves the right to update or make technical changes without prior notice.

**Standards and approvals**

VF and VFT types meet current European approval requirements regarding safety use on gaseous fuels. These products conform with the Gas Appliances Regulation (EU) 2016/426 and the tests have been carried out according to EN13611 standard.

**Certificate No.: 18GR0642/00**

The product complies with the Technical Regulation TP TC 004/2011-016/2011-020/2011-032/2013 of Russia, Belarus and Kazakhstan.

Certificate No.: TC № RU Д-IT.PA01.B.21942

**Quality Management System certified according to UNI EN ISO 9001.**